

**COVID-19 Vaccine
Toolkit for
Missouri Schools**



MISSOURI CHAPTER
AMERICAN ACADEMY OF PEDIATRICS
INCORPORATED IN MISSOURI

This toolkit was developed to provide Missouri schools with easily accessible information regarding the administration of the COVID-19 vaccine to eligible children. Currently, Missouri is vaccinating ages 5 and up. Schools are a place where children feel safe and secure. Providing the COVID-19 vaccine in the school setting is a way to ensure all children have access to this safe option for protecting against the virus.

While we do not recommend a one-size fits all approach for every school, we want to highlight the strategies that exist for schools that wish to pursue vaccination on the school campus. A key piece of vaccinating is community collaboration. We encourage you to reach out to your local public health department, pharmacy, hospital, pediatric or family practice to discuss ways to bring the vaccine safely to the children in your community. In some areas there may be established collaborations already in place to partner with schools. Planning & communicating are key pieces to any successful event. Providing an accessible opportunity for the families and children of your community is very important to increase vaccinations. As with all things, this pandemic is evolving, and information can change at any time. Please check the links provided below for updated guidance regarding COVID-19.

This toolkit was created with oversight from pediatric experts from across the state of Missouri and with input from local public health officials. Because guidance on vaccine administration changes frequently, be sure to follow all links in this document to obtain the most recent information and guidance available.

This is not a legal document. Obtain outside legal review, as needed. Updated May 2022.

Following is a checklist to offer the COVID-19 vaccine in the school setting. Schools are an ideal setting in providing equitable distribution of the vaccine. School based vaccination clinics decrease barriers to vaccination and increase vaccination rates.

	Action Plan	Completed
<p>Needs Assessment & Identification of Partners Assemble a school based team to assess the districts goals and needs, including volunteers needed for the day of the event. Identify potential partners in the community who can assist with the vaccine administration.</p>		
<p>Collaboration Collaborate with your school & community leaders – make sure key stakeholders are aware of your desire to offer the vaccine—school personnel including the school nurse, facilities manager, school security, school leadership, school communications staff, local parents as teachers organization, local health department, local pediatric or family practice, local hospital/healthcare system, FQHC, rural health clinic, or pharmacy. In the collaboration, decide who is responsible for the following pieces: obtaining vaccine, storing vaccine, obtaining consent, scheduling students and possibly family members to receive vaccine, drawing up vaccine, administering vaccine, observation post vaccine, and documentation of vaccine. Understanding roles and responsibilities is important.</p>		
<p>Agreement Determine if an agreement is required with the partnering agency that will vaccinate children. All parties involved should understand their roles and responsibilities to ensure you understand who is providing what services and the liability for those services. (Possibly a building or facility agreement).</p>		
<p>Equity Schools provide a venue for providing equitable distribution of the COVID-19 vaccine. We encourage you to include families and students as you develop an equitable vaccine communication process for the students at the school. Consider if you will also vaccinate parents or community members that have not yet been vaccinated, including students from other schools/districts.</p>		
<p>Consent There are multiple consent pieces to consider—consent for children receiving a vaccine and having parents consent to allow their child/children to be vaccinated, the need for parental presence or not, etc. Discuss the following with the appropriate people in your school/district:</p> <ul style="list-style-type: none"> • Will you accept verbal consent from parents, or do they need to be present at the time of vaccination? • What if parents disagree about providing consent? • What if a parent wants a child to be vaccinated but the child does not want the vaccine? • What if a child want the vaccine but the parent does not approve? • Will parents and other family members be offered the vaccine? <p>Consent needed from each person to receive vaccine. Work with your partnering organization to understand their consent process. Determine who will be responsible for gathering signed consent forms and determine what information will be shared between the vaccinator and school personnel. View more information about documentation here.</p>		
<p>Communication Determine how you will notify students and families of the vaccine event. We encourage you to include parents & students in the plan to ensure an equitable distribution of the vaccine. If you are scheduling appointments, state where an appointment can be scheduled. If you are offering a drive-up event, communicate the logistics. Provide a phone number for questions. Consider including a copy of the consent form in the communication and work with the partnering organization on the best way to gather consent forms. Communicate the details of the event multiple times and via different formats to ensure widespread knowledge of the event, including information about the vaccines. Consider sharing information about the event upon its conclusion. Share information on regular childhood immunizations and encourage parents to schedule a time to receive any missed vaccinations. Communicate with the primary care physicians in your community to ensure they are aware of the event. Immunization schedules link.</p> <p>Be clear on the timing & dates for the second dose schedule and provide a number to call if the second dose appointment cannot be kept.</p> <p>Send the CDC Frequently Asked Question document to COVID-19 Vaccine Adolescent and Child FAQ to parents before the scheduled vaccine when sending the consent form and the appropriate EUA. Provide the V-Safe information to the parent/adolescent ahead of time so they may enroll in this free safety surveillance program.</p> <p>Review the CDC’s information on Myths and Facts related to the COVID-19 vaccine: Myths and Facts about COVID-19 Vaccines CDC</p>		

	Action Plan	Completed
<p>Space Determine an appropriate space for the vaccine site You will need:</p> <ol style="list-style-type: none"> 1. Check-in area. Determine what supplies are needed here. Consider extra consent forms, copy machine. 2. A small space to draw up vaccine, ideally visually away from the children and free from distractions. Work with your partner organization to determine where a refrigerator to store the vaccine will be located. Determine if you will need a separate refrigerator for any drawn vaccine. 3. A space to administer vaccine with tables and chairs (consider outlets if computers are used to document administration) 4. An observation area with chairs for people to sit following vaccine administration, include enough room to account for children and any family members there with them. Space children and families 6 feet apart. 5. Consider a private area or space to address an adverse reaction. 6. Assess the Internet access in the area. 7. Space for bottled water and snacks. <p>This may determine how many students can be vaccinated at any given time.</p>		
<p>Emergencies Consider emergency needs and have a preparedness plan in place. Emergency medications such as Epi-pens need to be readily available. Staff members should be certified to perform CPR. Inform your local EMS provider of the event.</p> <p>Review the process to call for emergency assistance (911) and how emergency personnel will access the observation area in the event that a child has an anaphylactic reaction.</p> <p>Communicate with primary care physicians in the area about the vaccine event, so they can communicate with the school regarding any issues or questions they treat in clinic.</p>		
<p>Schedule Determine how to best schedule the students for vaccine to minimize the disruption of their education and protect their personal decisions to receive vaccine or not. Consider a sign-up sheet with consent forms on file to assist in planning for number of doses needed on the day of the event.</p> <p>Consider needs for scheduling the second dose of vaccine if required and how best to facilitate that process when scheduling the first vaccine. Make a plan for those who cannot attend for the second dose. at the prescribed time. Make a plan with the partner organization for scheduling second doses that cannot take place at the prescribed time.</p> <p>Review with the staff giving vaccine their experience and usual rate of vaccination to determine spacing of students.</p>		
<p>Storage Consider storage of vaccine and if this will be onsite. If the vaccine event is occurring over multiple days, discuss plans for overnight storage.</p> <p>Storage of any vaccine overnight is not allowed. The provider will need to take the vaccine back after the close of the clinic each day.</p> <p>All off site clinics should be utilizing this offsite clinic checklist to ensure vaccine viability. https://www.izsummitpartners.org/content/uploads/2019/02/off-site-vaccination-clinic-checklist.pdf</p>		
<p>Drawing Up Vaccine Consider who will be drawing up vaccine. All staff who will be responsible for administrating or preparing vaccine for administration need to complete the CDC online trainings for the vaccine that is being utilized. Review the CDC information for the vaccine you are using.</p> <p>Pfizer: https://www.cdc.gov/vaccines/covid-19/info-by-product/pfizer/downloads/prep-and-admin-summary.pdf</p> <p>Moderna: https://www.cdc.gov/vaccines/covid-19/info-by-product/moderna/downloads/prep-and-admin-summary.pdf</p>		
<p>Draw Station Discuss which supplies need to be present at the vaccine draw station.</p>		

	Action Plan	Completed
<p>Administering Vaccine Consider who will administer vaccine. Vaccine administrators must complete required training for the COVID-19 vaccine. COVID-19 Vaccine: Vaccine Administration Competencies Assessment Form-February 28, 2021 (cdc.gov)</p> <p>Vaccine Administration Protocols CDC</p> <p>Discuss which supplies need to be available at the vaccine administration tables.</p> <p>CDC Guidance regarding vaccine administration spacing—Yes, it is considered safe to coadminister the COVID-19 and other vaccines at the same time. See “Vaccine Schedule and Use” section: COVID-19 Vaccine FAQs for Healthcare Professionals CDC</p>		
<p>Documentation Determine the process for entering all vaccine administration into Show Me Vax and ensure all parties are clear on responsibility. Show Me Vax entry is a critical step to document vaccine, in the event a vaccine card is lost. Work with your partner to determine if an insurance card is needed at the time of vaccine administration.</p> <p>Develop a plan for the child’s vaccine card to ensure it is not lost between school and home. Consider storing vaccine cards at the school until second dose. Develop a plan for parents to access vaccine cards. Advise families on how to protect their child’s vaccination card and develop a plan to keep the cards from becoming lost if vaccinating children when their caregivers are not present. Have a clear communication plan for students regarding bullying prevention on having or not having vaccination/card.</p>		

Resources

For additional information on the COVID-19 vaccine resources are provided below to help you find answers to your questions.

[Missouri Department of Health & Senior Services Standing Orders](#)

[Missouri COVID-19 Vaccination Consent Form – Ages 12 & up](#)

[Missouri Department of Health & Senior Services Mobile Vaccine Unit Scheduling](#)

[Find a COVID Vaccine in Missouri](#)

[Missouri Local Public Health Department Directory](#)

[Community Health Center Directory](#)

[Missouri’s COVID-19 Vaccine Plan](#)

[Missouri-Plain-Language-Guide-COVID-19-Vaccine-for-Individuals-with-Intellectual-and-Developmental-Disabilities-Their-Families-Caregivers-in-Missouri.pdf \(moddcouncil.org\)](#)

Kaiser Permanente & the National School Nurse Association—[Managing a COVID-19 vaccine clinic at a school site \(sbh4all.org\)](#)

[Preparing for a School-Located COVID-19 Vaccination Clinic - Katherine Park, Rebecca Cartmill, Belinda Johnson-Gordon, Mary Landes, Karen Malik, Jane Sinnott, Kathy Wallace, Robin Wallin, 2021 \(sagepub.com\)](#)

[COVID-19 Infection Prevention and Control: Frequently Asked Questions \(aap.org\)](#)

[Children’s Mercy COVID Vaccine FAQs](#)

[Guidance for Operating Youth Camps \(cdc.gov\)](#)

[Interim Public Health Recommendations for Fully Vaccinated People | CDC](#)

[Pfizer Storage & Handling Summary](#)

[Moderna Storage and Handling Summary](#)

[Janssen Storage & Handling Summary](#)

[Birth to 6 years vaccination schedule](#)

[7-18 years vaccination schedule](#)

CDC Printable Resources

[Stickers for Vaccine Recipients—Print Resources | CDC](#)

[Stopping the COVID-19 Pandemic Is Going to Take All of Our Tools \(cdc.gov\)](#)

[COVID-19 Vaccines are one of the tools we have to fight the COVID-19 Pandemic \(cdc.gov\)](#)

[COVID-19 Vaccine Toolkit for Staff in School Settings and Childcare Programs](#)

[What to Expect after Getting a COVID-19 Vaccine \(cdc.gov\)](#)

[Considerations for Planning School-Located Vaccination Clinics | CDC](#)

[Answering Patients’ Questions about COVID-19 Vaccination | CDC](#)

Parent Resources

[Getting Your Child Ready for the COVID-19 Vaccine—HealthyChildren.org](#)

[When can children get the COVID-19 vaccine?—HealthyChildren.org](#)

[Does the COVID-19 vaccine cause myocarditis?—HealthyChildren.org](#)

[The COVID-19 Vaccine and Fertility—ChildrensMD](#)

[Mental Health During COVID-19: Signs Your Child May Need More Support—HealthyChildren.org](#)

[Should Your Child Be Tested for COVID-19?—HealthyChildren.org](#)

[The Science Behind COVID-19 Vaccines: Parent FAQs—HealthyChildren.org](#)

More resources can be found at [HealthyChildren.org](#).

Vaccination Clinic with interior access only

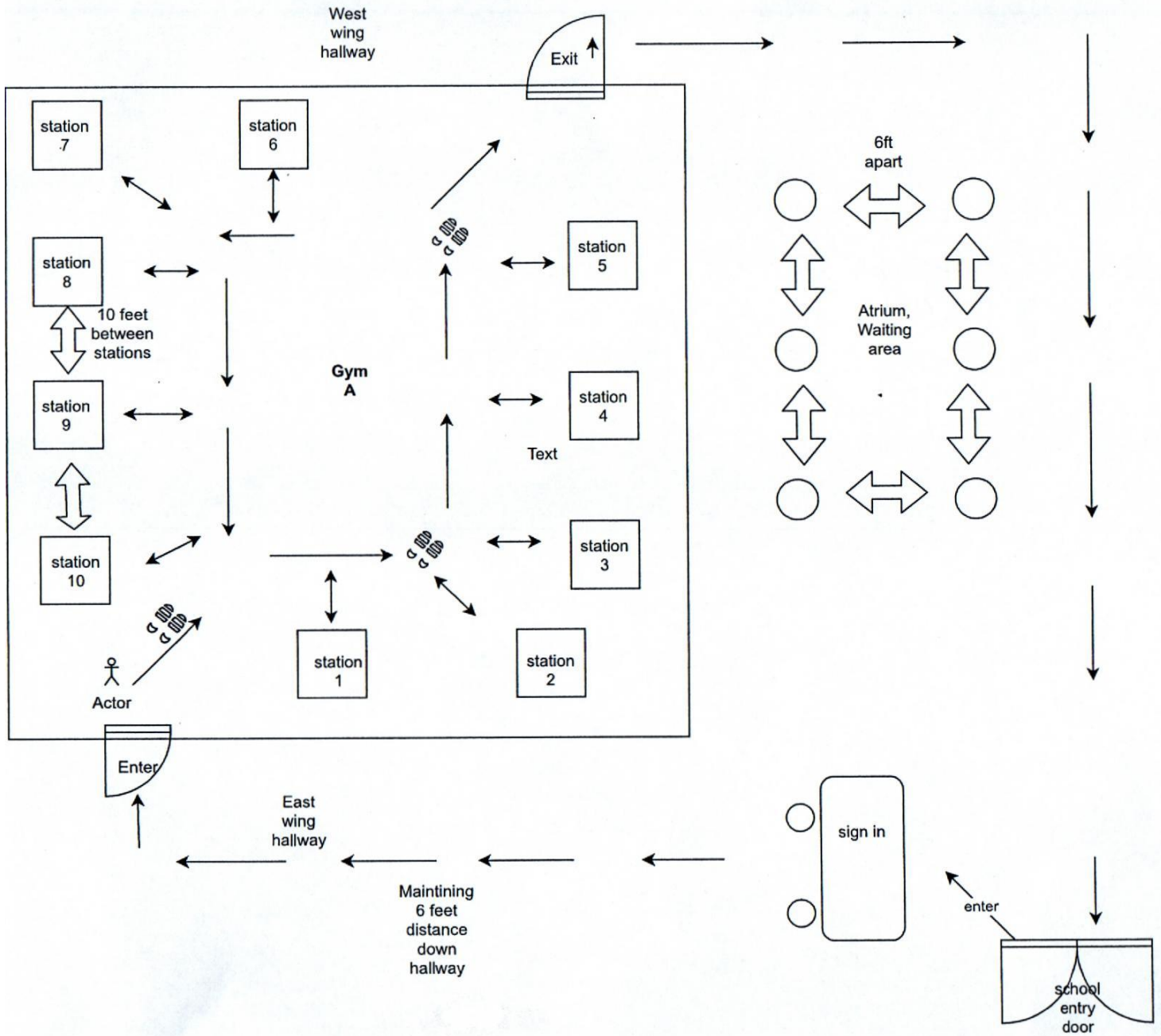

Example Email Text

Dear Parents,

We are excited to announce (INSERT SCHOOL) is making space available for the (PARTNERING ORGANIZATION) staff to administer the (PFIZER OR MODERNA) COVID-19 vaccine for students age (INSERT AGE) and older with parental consent.

The event will be held at (INSERT LOCATION) on (DATE) (TIME) with a return visit for the second dose on (DATE). If you are interested in your student (age XX) participating in this vaccine clinic, please confirm by answering (INSERT SURVEY LINK). Please complete this form by (TIME), (INSERT DATE) to secure your vaccine dose, if interested.

We are working to provide additional dates and opportunities for our eligible students to be vaccinated, if needed, after this event. It's also important to know this is one optional opportunity for students. There are currently many other vaccination events and locations throughout our community. To find other opportunities, visit [Vaccine Finder](#).

If you have any questions about this event, please contact (ENTER NAME & EMAIL).